



Parallel Robot

D3PM-3/1300-320

The standard cycle time is less than 0.4s to meet the demand for maximum speed and economics.

Rotary servo motor is installed on moving platform to meet the requirements of high-precision rotary operation easily

Widely used in the food and beverage, pharmaceutical, electron, and healthcare industries of small workpieces for handling, sorting, measuring, assembling, inspecting, testing and other applications

SPECIFICATIONS

Robot Version D3PM-3/1300-320

Axes. 3+1

Maximum Payload 3kg

Maximum Working Diameter 1300 mm

Working Height 320 mm

Rotation Angle $\pm 360^\circ$

Mounting Inverted

Manipulator Weight 86.5kg

Angle Range of Active Arm

Upper Arm 31.5°

Lower Arm 74°

Position Repeatability ± 0.05 mm

Angular Repeatability $\pm 0.05^\circ$

Max. Load Moment of Inertia 31×10^{-4} kg.m²

Power Requirements

Supply Voltage 220V/380V/3-Phase 220V/1-Phase 49-61 HZ

Rated Power 6.1 kW

Transformer rating 10kVA

Environment Requirements

Storage Temperature $-10^\circ\text{C} \sim 70^\circ\text{C}$

Working Temperature $-10^\circ\text{C} \sim 50^\circ\text{C}$

Humidity Range Max. 90%

Protection IP55





LOAD-FREQUENCY

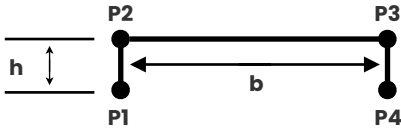

Trajectory 1 $h=25, b=305$ P1 - P2 - P3 - P4 - P3 - P2 - P1
 Trajectory 2 $h=25, b=305$ P1 - P2 - P3 - P4 - P3 - P2 - P1
 Trajectory 3 $h=25, b=305$ P1 - P2 - P3 - P2 - P1
 Trajectory 4 $h=25, b=305$ P1 - P2 - P3 - P2 - P1

Cycles/min	0.00kg	0.50kg	1.00kg	1.50kg	2.00kg	2.50kg	3.00kg
Trajectory 1	175.50	163.80	157.95	128.70	117.00	105.30	93.60
Trajectory 2	152.10	146.25	111.15	99.45	93.60	76.05	64.35
Trajectory 3	201.83	188.37	181.64	148.01	134.55	121.10	107.64
Trajectory 4	171.87	165.26	125.60	112.38	105.77	85.94	72.72

The cycle times are measured under real conditions, but may vary depending on the actual application.

Dimensions & Range of Motion (mm)

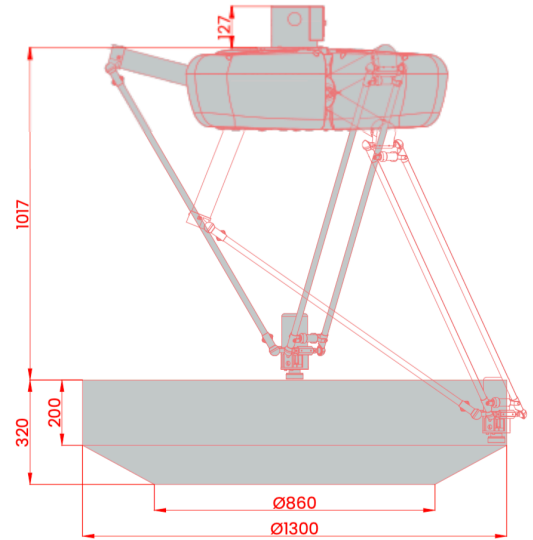

Flange (mm)

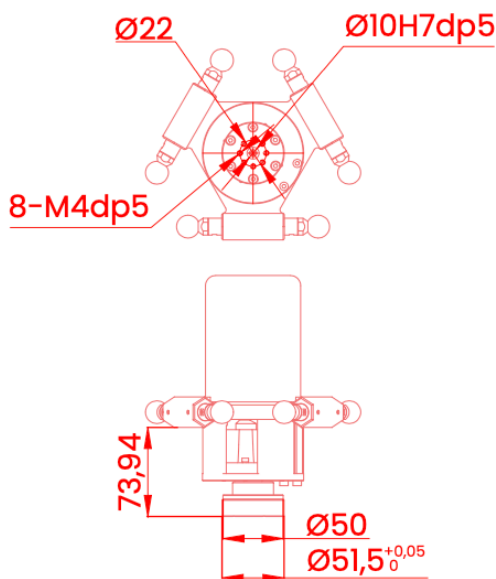

Mounting Base (mm)

