



Parallel Robot

D3P-3/1200-340

The standard cycle time is less than 0.4s to meet the demand for maximum speed and economics.

Special rotation axis hinge design easily meet the needs of high-intensity high-frequency repetitive motion.

Widely used in space-constrained occasions of the food and beverage, pharmaceutical, and healthcare industries for picking, packaging and handling.



SPECIFICATIONS

Robot Version D3P-3/1200-340

Axes. 3+1

Maximum Payload 3kg

Maximum Working Diameter 1200 mm

Working Height 340 mm

Rotation Angle $\pm 360^\circ$

Mounting Inverted

Manipulator Weight 80.6 kg

Angle Range of Active Arm

Upper Arm 34.5°

Lower Arm 86.5°

Position Repeatability ± 0.05 mm

Angular Repeatability $\pm 0.1^\circ$

Max. Load Moment of Inertia 31×10^{-4} kg.m²

Power Requirements

Supply Voltage 220V/380V/3-Phase 220V/1-Phase 49-61 HZ

Rated Power 6.1 kW

Transformer rating 10kVA

Environment Requirements

Storage Temperature $-10^\circ\text{C} \sim 70^\circ\text{C}$

Working Temperature $-10^\circ\text{C} \sim 50^\circ\text{C}$

Humidity Range Max. 90%

Protection IP55



LOAD-FREQUENCY

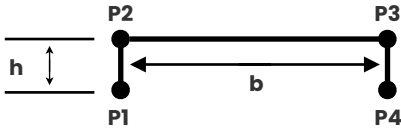

- Trajectory 1 h=25,b=305 P1 - P2 - P3 - P4 - P3 - P2 - P1
- Trajectory 2 h=25,b=305 P1 - P2 - P3 - P4 - P3 - P2 - P1
- Trajectory 3 h=25,b=305 P1 - P2 - P3 - P2 - P1
- Trajectory 4 h=25,b=305 P1 - P2 - P3 - P2 - P1

Cycles/min	0.00kg	0.50kg	1.00kg	1.50kg	2.00kg	2.50kg	3.00kg
Trajectory 1	195.00	182.00	175.50	143.00	130.00	117.00	104.00
Trajectory 2	169.00	162.50	123.50	110.50	104.00	84.50	71.50
Trajectory 3	234.00	218.40	210.60	171.60	156.00	140.40	124.80
Trajectory 4	190.97	183.63	139.56	124.87	117.52	95.49	80.80

The cycle times are measured under real conditions, but may vary depending on the actual application.

Dimensions & Range of Motion (mm)

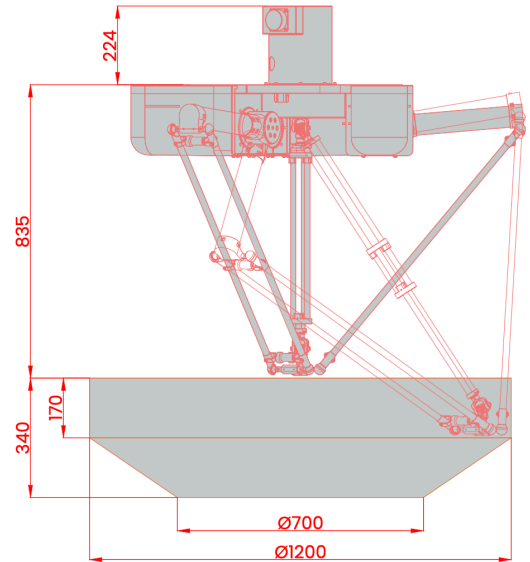

Flange (mm)

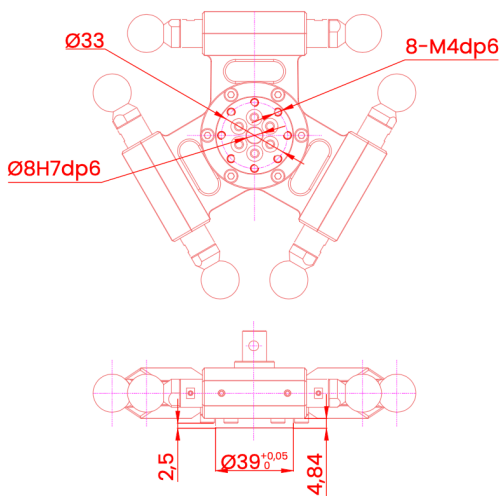

Mounting Base (mm)

