



## Parallel Robot

# D3P-3/1100-320

The standard cycle time is less than 0.45s to meet the demand for maximum speed and economics.

Special rotation axis hinge design easily meet the needs of high-intensity high-frequency repetitive motion.

Widely used in the food and beverage, pharmaceutical, and healthcare industries of small materials for picking, packaging and handling.



## SPECIFICATIONS

Robot Version D3P-3/1100-320

Axes. 3+1

Maximum Payload 3kg

Maximum Working Diameter 1100 mm

Working Height 320 mm

Rotation Angle  $\pm 360^\circ$

Mounting Inverted

Manipulator Weight 85.5 kg

Angle Range of Active Arm

Upper Arm  $39.2^\circ$

Lower Arm  $77.1^\circ$

Position Repeatability  $\pm 0.05$  mm

Angular Repeatability  $\pm 0.1^\circ$

Max. Load Moment of Inertia  $31 \times 10^{-4}$  kg.m<sup>2</sup>

Power Requirements

Supply Voltage 220V/380V/3-Phase 220V/1-Phase 49-61 HZ

Rated Power 6.1 kW

Transformer rating 10kVA

Environment Requirements

Storage Temperature  $-10^\circ\text{C} \sim 70^\circ\text{C}$

Working Temperature  $-10^\circ\text{C} \sim 50^\circ\text{C}$

Humidity Range Max. 90%

Protection IP55



## LOAD-FREQUENCY

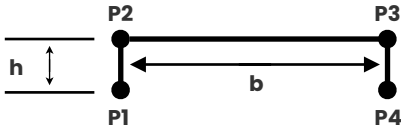

Trajectory 1  $h=25, b=305$  P1 - P2 - P3 - P4 - P3 - P2 - P1  
 Trajectory 2  $h=25, b=305$  P1 - P2 - P3 - P4 - P3 - P2 - P1  
 Trajectory 3  $h=25, b=305$  P1 - P2 - P3 - P2 - P1  
 Trajectory 4  $h=25, b=305$  P1 - P2 - P3 - P2 - P1

Cycles/min	0.00kg	0.50kg	1.00kg	1.50kg	2.00kg	2.50kg	3.00kg
Trajectory 1	169.00	156.00	123.50	110.50	104.00	91.00	78.00
Trajectory 2	156.00	149.50	110.50	97.50	91.00	78.00	65.00
Trajectory 3	202.80	187.20	148.20	132.60	124.80	109.20	93.60
Trajectory 4	176.28	168.94	124.87	110.18	102.83	88.14	73.45

The cycle times are measured under real conditions, but may vary depending on the actual application.

## Dimensions & Range of Motion (mm)

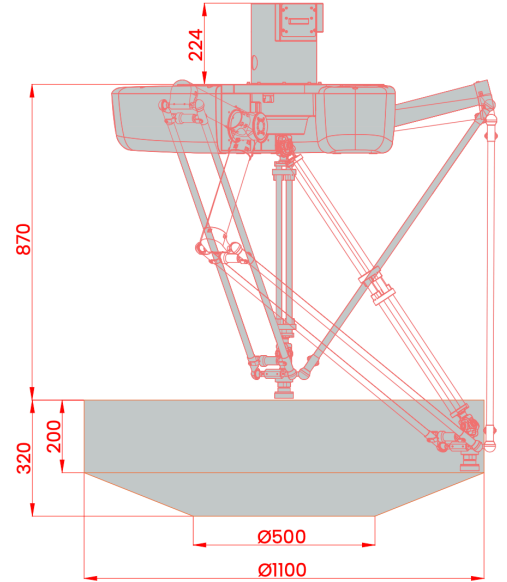

## Flange (mm)

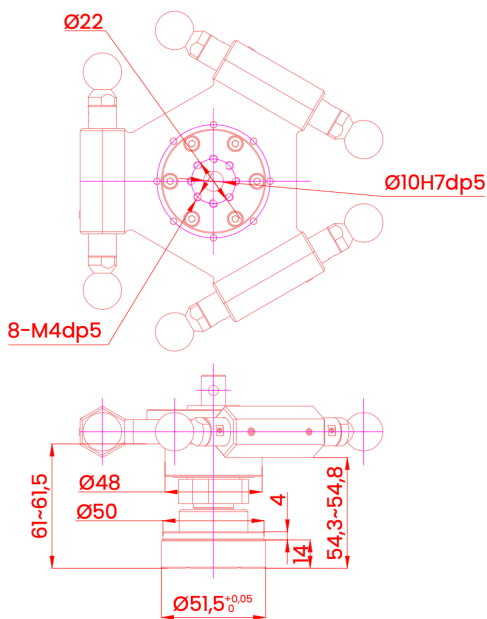

## Mounting Base (mm)

