



## Parallel Robot

# D3P-8/1100-300

The standard cycle time is less than 0.6s to meet the demand for maximum load and economics.

Special rotation axis hinge design easily meet the needs of high-intensity high-frequency repetitive motion.

Widely used in the food and beverage, pharmaceutical, and healthcare industries of heavy materials for picking, packaging and handling.



## SPECIFICATIONS

Robot Version D3P-8/1100-300

Axes. 3+1

Maximum Payload 8kg

Maximum Working Diameter 1100 mm

Working Height 300 mm

Rotation Angle  $\pm 360^\circ$

Mounting Inverted

Manipulator Weight 128 kg

Angle Range of Active Arm

Upper Arm  $13.5^\circ$

Lower Arm  $78.5^\circ$

Position Repeatability  $\pm 0.05$  mm

Angular Repeatability  $\pm 0.1^\circ$

Max. Load Moment of Inertia  $250 \times 10^{-4}$  kg.m<sup>2</sup>

Power Requirements

Supply Voltage 220V/380V/3-Phase 220V/1-Phase 49-61 HZ

Rated Power 6.1 kW

Transformer rating 10kVA

Environment Requirements

Storage Temperature  $-10^\circ\text{C} \sim 70^\circ\text{C}$

Working Temperature  $-10^\circ\text{C} \sim 50^\circ\text{C}$

Humidity Range Max. 90%

Protection IP55



## LOAD-FREQUENCY

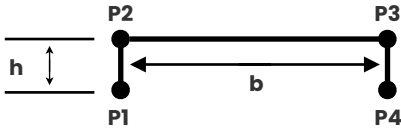

- Trajectory 1 h=25,b=305 P1 - P2 - P3 - P4 - P3 - P2 - P1
- Trajectory 2 h=25,b=305 P1 - P2 - P3 - P4 - P3 - P2 - P1
- Trajectory 3 h=25,b=305 P1 - P2 - P3 - P2 - P1
- Trajectory 4 h=25,b=305 P1 - P2 - P3 - P2 - P1

Cycles/min	0.00kg	1.00kg	2.00kg	3.00kg	4.00kg	5.00kg	6.00kg	7.00kg	8.00kg
Trajectory 1	117.00	117.00	104.00	97.50	78.00	65.00	52.00	45.5	39
Trajectory 2	104.00	104.00	91.00	84.50	65.00	52.00	45.50	39	32.5
Trajectory 3	134.55	134.55	119.60	112.13	89.70	74.75	59.80	52.325	44.85
Trajectory 4	114.40	114.40	100.10	92.95	71.50	57.20	50.05	42.9	35.75

The cycle times are measured under real conditions, but may vary depending on the actual application.

## Dimensions & Range of Motion (mm)

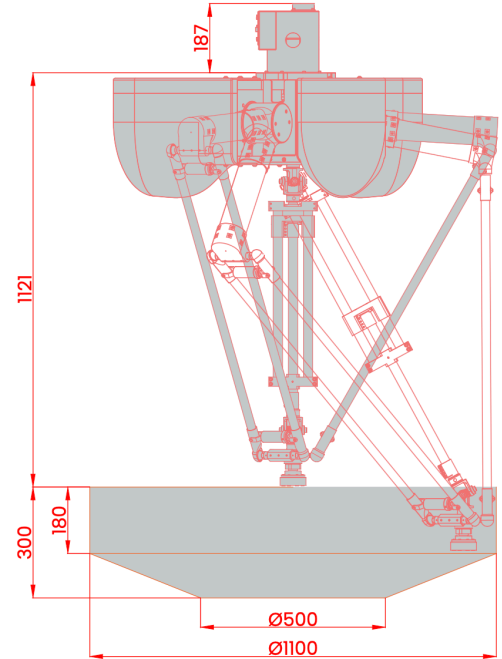

## Flange (mm)

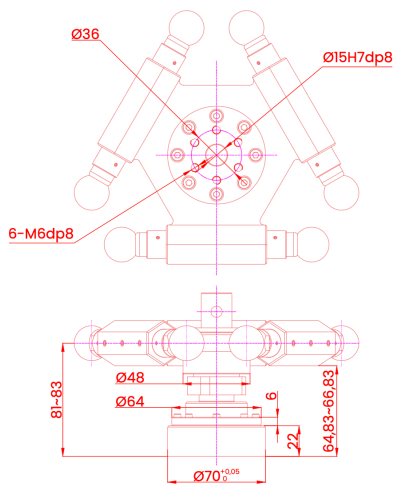

## Mounting Base (mm)

